

Specification

Model S100D

P/N SD-H60NB-1A8

- True VGA ToF camera module
- Compact design

S100D image of the development version

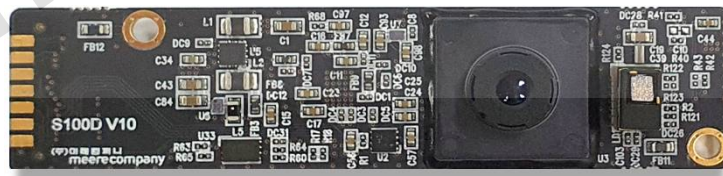

Revision History

Date	Ref. Page	Description	Remark
20-09-09	-	Draft write	
21-01-21	-	Added I2C protocol	
	-	Added register map	
	-	Added embedded data information	
	-	Data format change	
	-	Added cover glass guide	
21-06-02	9, 22	Storage temperature, Rockchip information	
	29	Host board connector	
21-07-15	36	Changed Host board connector	
21-07-20	29, 36	Changed Host board connector	

meerecompany

Contents

1	Introduction	7
1.1	ToF 3D camera technology overview	7
1.2	System block diagram	8
2	General Specification	9
3	Component Specification	10
3.1	Main component	10
3.2	MR1000 calculating depth	10
4	Functional Specification	11
4.1	MIPI CSI-2 output	11
4.2	High speed depth calculation using MR1000	11
5	Operation	12
5.1	Initialization	12
5.2	Operation(Boot) Mode	12
6	I2C Control Protocol	14
6.1	Protocol description	14
6.2	Example	15
7	MIPI interface	16
7.1	MIPI TX specification	16
8	Register map	17
8.1	Register information	17
8.2	Register description	18
8.2.1	Amplitude threshold control registers	18
8.2.2	Depth threshold control registers	18
8.2.3	Scattering threshold control registers	18
8.2.4	Depth error threshold control registers	18
8.2.5	Image filter control registers	19
8.2.6	Depth offset control registers	19
8.2.7	Motion blur control registers	20
8.2.8	Multi camera interference control registers	20
8.2.9	Output data format control registers	21
8.2.10	Information register	21
9	Software(SDK)	22
9.1	Conditions of the example code	22
9.2	CubeEye software development kit	22

Contents

10	System Integration	23
10.1	System level block diagram	23
10.2	System Power	23
10.3	B to B connector pin map	24
10.4	B to B connector pin information	25
11	Design Guidelines	26
11.1	LVDS line PCB design guide (mandatory)	26
11.2	MIPI signals artwork guide	26
11.3	Notes on design	26
12	Mechanical Drawings	27
12.1	Schematic	27
12.2	Physical z=0 plane	27
13	Connector Drawings	28
13.1	S100D B to B connector	28
13.2	Host B to B connector	29
14	Certification	30
14.1	Eye safety	30
Appendix A : Data format		31
A.1	Data format	31
A.1.1	1 pixel format	31
A.1.2	16 bits data format	31
A.2	Mode example	32
A.3	Embedded line data description	33
Appendix B : USB3.0 bridge board(U300)		34
B.1	Block diagram	34
B.2	S100D on U300	34
B.3	U300 schematic	35
B.4	U300 connector pin map	36
B.5	U300 connector pin information	37
B.6	Accessories	38
B.7	Cable connection	38
Appendix C : Part number		39
Appendix D : Cover Glass Assy' Guide		40

Figures

Fig 1.	Principles of indirect Time of Flight	7
Fig 2.	ToF demodulation using 4-phase sampling	7
Fig 3.	System block diagram	8
Fig 4.	MR1000 block diagram	10
Fig 5.	Power on sequence, sensor boot time	12
Fig 6.	Boot mode diagram	13
Fig 7.	MIPI TX operation TX signal timing	16
Fig 8.	S100D system block diagram	23
Fig 9.	S100D system power	23
Fig 10.	B to B connector No.1 position	24
Fig 11.	Host PCB LVDS line design guide	26
Fig 12.	S100D dimension and schematic	27
Fig 13.	Physical z=0 plane	27
Fig 14.	S100D connector	28
Fig 15.	Host board Connector	29
Fig 16.	Data reconstruction	31
Fig 17.	Output mode examples	32
Fig 18.	U300 block diagram	34
Fig 19.	Combined S100D and U300	34
Fig 20.	U300 dimension	35
Fig 21.	U300 B to B connector	36
Fig 22.	U300 accessories	38
Fig 23.	Cable connection	38
Fig 24.	Decription of the part number configuration	39
Fig 25.	Example image of use of cover glass	40

Tables

Table 1.	Main parts specification summary	8
Table 2.	Information of general specification	9
Table 3.	Main components description	10
Table 4.	Operation mode description	12
Table 5.	Protocol header	14
Table 6.	Protocol action	14
Table 7.	Protocol write	15
Table 8.	Protocol read	15
Table 9.	Register information	17
Table 10.	Amplitude threshold register setting	18
Table 11.	Depth threshold register setting	18
Table 12.	Scattering threshold register setting	18
Table 13.	Depth error threshold register setting	18
Table 14.	Image filter register setting	19
Table 15.	Depth offset register setting	19
Table 16.	Motion blur register setting	20
Table 17.	Multi camera interference reducing register setting	20
Table 18.	Output data format register setting	21
Table 19.	Module information register	21
Table 20.	B to B connector pin map	24
Table 21.	B to B connector pin information	25
Table 22.	Eyesafety standard information	30
Table 23.	Data mode	31
Table 24.	Embedded line data description	33
Table 25.	U300 B to B connector pin map	36
Table 26.	U300 pin information	37

1. Introduction

1.1. ToF 3D technology overview

3D time-of-flight (ToF) cameras illuminate an object or a scene with a modulated light source and observe the light reflected from the object. This is achieved via a laser diode illuminator and a receiver. The phase shift between the emitted light and reflected light is measured and translated to distance. This camera can measure an object's distance by pixel unit.

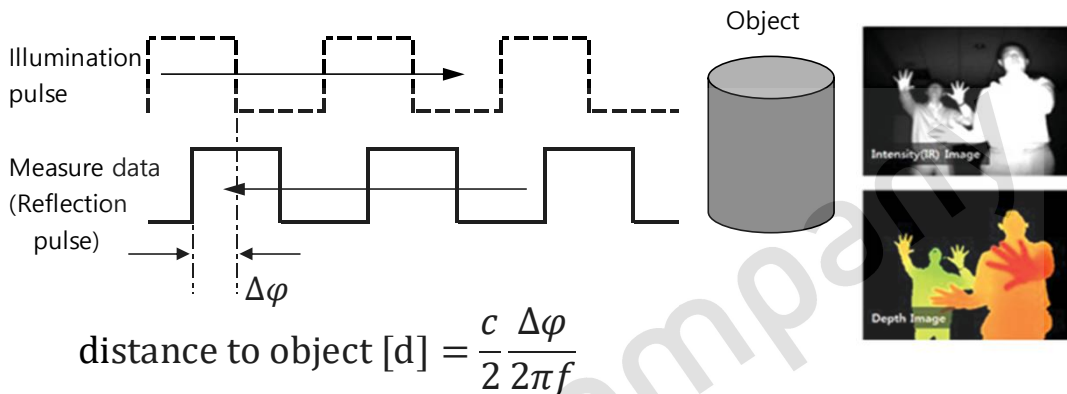
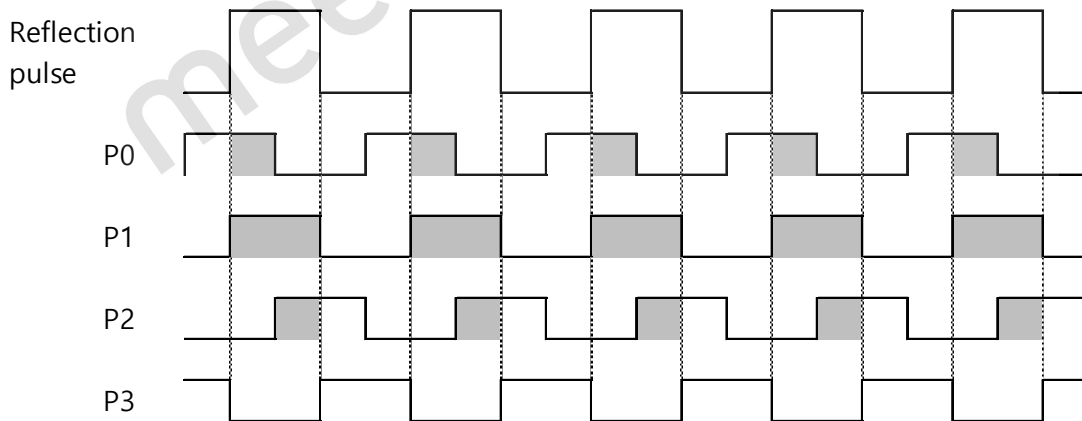

Fig 1. Principles of indirect Time of Flight



A0 is digital value measured at the P0 photogate $\varphi = \tan^{-1}\left(\frac{A_1 - A_3}{A_0 - A_2}\right)$

Fig 2. ToF demodulation using 4-phase sampling

1. Introduction

1.2. System block diagram

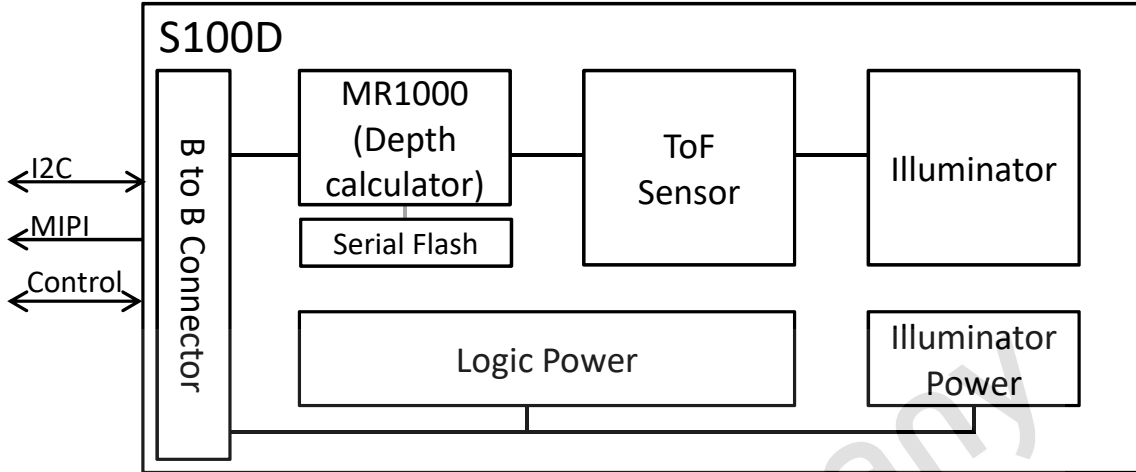

Fig 3. System block diagram

Parts	Summary
Illuminator	2W VCSEL(package with PD)
ToF sensor	VGA, 4 phase data out, global shutter
MR1000	Depth calculation
Serial Flash	MR1000 bootloader, calibration parameter
Power	Illuminator/Sensor/MR1000 Power
B to B Connector	Connector for host interface

Table 1. Main parts specification summary

2. General Specification

ToF Sensor		
Type of sensor	Samsung System LSI S5K33DXX	
Resolution	VGA (640x480), unit pixel size : 7.0 um	
Illumination		
Source	2W VCSEL	
Wavelength	940 nm	
Modulation frequency	80 MHz, 100 MHz	
Optics		
FOV (H x V)	60° x 45°	
Measurement range	0.2 ~ 4.0 m	
Accuracy		
0.2 ~ 0.5 m	< ± 10 mm	※ Measurement condition - Target : flat screen of >70 % reflectivity - Target area : 7x7 central pixels - Number of data acquisition : 20 frames - Ambient illumination : normal indoor - Ambient temperature : 23 ~ 25°C
0.5 ~ 4.0 m	< ± 1% by distance	
Interface		
Control interface	I2C 400 Kbps	
Data interface	MIPI CSI-2 2 lanes, 500 Mbps/lane	
Power		
Input	DC 5V 3A	
Power consumption	Average 1.5 W, peak 15 W (TBD)	
Temperature		
Operating Tem.	0 ~ 60°C	
Storage Tem.	-20 ~ 70°C	
Size		
Dimensions	60.0 x 15.0 x 10.1 mm ³	
Weight	(TBD)	
USB 3.0 Bridge board (Option)		
Dimensions	50.0 x 23.0 x 8.6 mm ³	
Interface	USB 3.0 C type	
Input power	DC 5V 5A (adaptor)	
Software (SDK for USB connecting user)		
Operation system	Windows 10, Ubuntu	
Output data	Raw 10 bits	

Table 2. Information of general specification

3. Component Specification

3.1. Main component

ToF sensor	VGA, 4:3 ratio, Active area 1/3.2"
	Electric global shutter
	ADC accuracy : 10bits
	Control I2C : max 1 MHz
Lens	F number : 1.4
	Focal Length : 3.92mm
	Horizontal Field of View : 60°
	Vertical Field of View : 45°
Illuminator	Illuminator wavelength : 940 nm
	SIP configuration : VCSEL, diffuser, VCSEL driver IC, PD
	Laser compliance : Eyesafety class 1

Table 3. Main components description

3.2. MR1000 calculating depth

There are 2 lanes of each Rx/Tx of MIPI on-chip in MR1000. It also contains depth engine, image correction, post image filter, cartesian coordinate conversion and memory for frame buffer as well as memory controller.

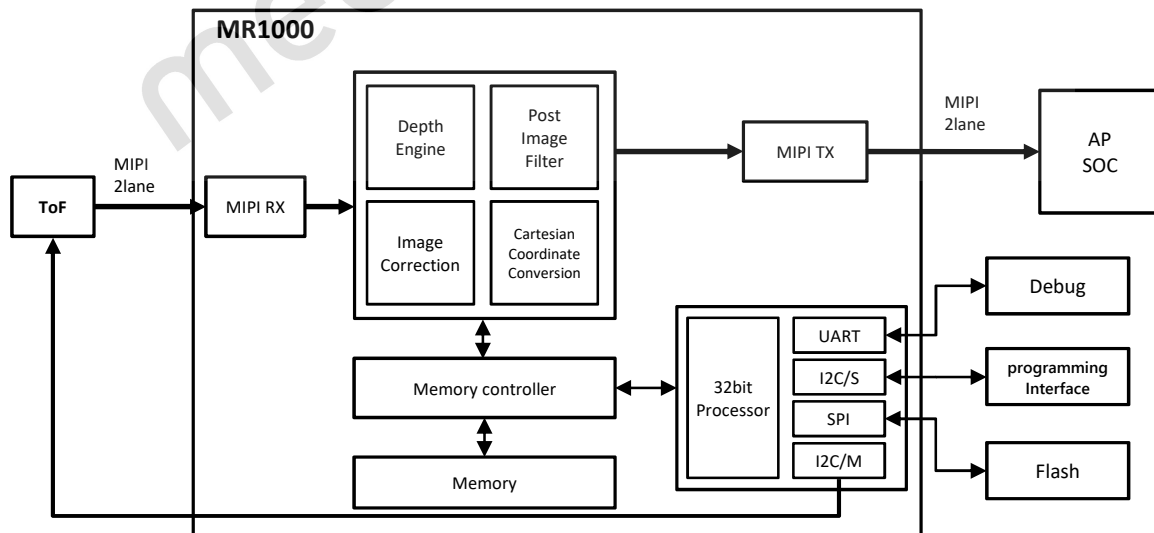

Fig 4. MR1000 block diagram

4. Functional Specification

4.1. MIPI CSI-2 output

- Support MIPI DPHY v1.1 and MIPI CSI-2 v1.1 RAW10
- 80Mbps to 500Mbps with 2-lane selectable

4.2. High speed depth calculation using MR1000

- Support resolution VGA
- Depth calculation in spherical coordinate
- Amplitude/Intensity data output
- Depth correction
- Temperature compensation
- Low motion blur(Single frequency mode)
- Noise/TNR/spatial filter selectable
- Cartesian coordinate conversion(Point cloud)

meerecompany

5. Operation

5.1. Initialization

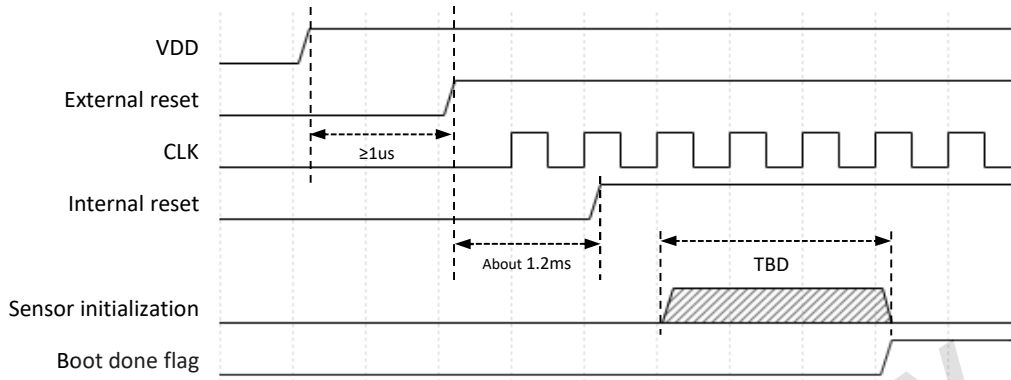

Fig 5. Power on sequence, sensor boot time

After power on, and when external reset is "High", CLK comes in and internal reset will be "High" after 1200 us (CLK at 24 MHz standard). All processes will work when the internal reset is high.

Booting is complete if the status of the boot done flag is '1'. Proceed with protocol work after checking boot done register status.

5.2. Operation(Boot) Mode

Mode	Description	Switching time	Power consumption
S3	Sleep mode : Minimum power consumption	off → S3 100 ms under	280 mW
S2	Retention mode : Minimum boot time	S3 → S2 1150 ms	340 mW
S1	Stand-by mode : Active ready	S2 → S1 290 ms	430 mW

Table 4. Operation mode description

5. Operation

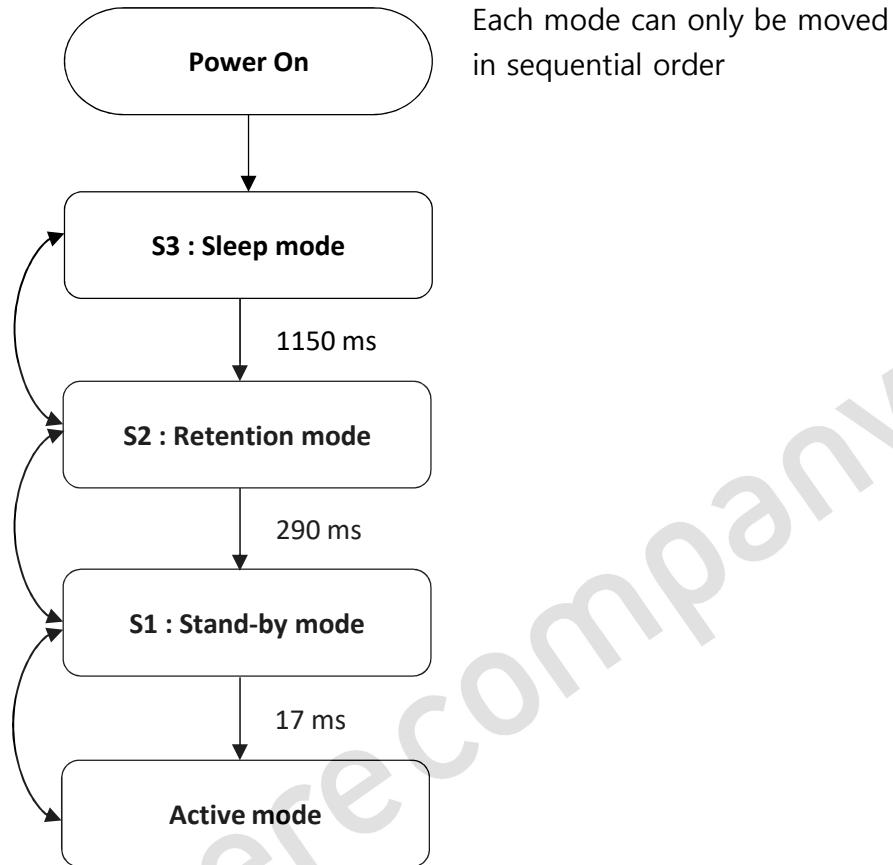

Fig 6. Boot mode diagram

6. I2C Control Protocol

6.1. Protocol description

Description	Start		Length		CMD		Address				Check sum		Data
Size(Byte)	2		2		2		4				2		0~63
Byte order	0	1	2	3	4	5	6	7	8	9	10	11	12-76
	L	H	L	H	L	H	L	H	L	H	L	H	L-H

Table 5. Protocol header

Action	Start	Length	CMD	Address	Check sum	Data
Register setting	0xB0A1	0x0002	0x0006	0x0000****	0x0000	0x****
Illumination	0xB0A1	0x0001	0x0007	0x00000000	0x0000	1:ON, 0:OFF
MIPI TX Mode	0xB0A1	0x0001	0x0009	0x00000000	0x0000	0 : 2560 1 : 1280 2 : 640
MIPI TX reset	0xB0A1	0x0001	0x000A	0x00000000	0x0000	1
Auto exposure	0xB0A1	0x0001	0x000C	0x00000000	0x0000	1:ON, 0:OFF
Sleep mode	0xB0A1	0x0001	0x000D	0x00000000	0x0000	0 : Active 1 : S1 2 : S2 3 : S3
Register reset (default)	0xB0A1	0x0001	0x000E	0x00000000	0x0000	1

Table 6. Protocol action

6. I2C Control Protocol

6.2. Example

Slave address 0xE0 (Write)

0xE1 (Read)

Ex1) Register write(address 0x1122, data 0x33445566)

Protocol name	Slave	Start	Length	CMD	Address	Check sum	Data							
Byte order(Write)	-	0	1	2	3	4	5	6	7	8	9	10	11	12
Register write	0xE0	0xA1	0xB0	0x01	0x00	0x06	0x00	0x22	0x11	0x00	0x00	0x00	0x00	0x66554433
Illumination on	0xE0	0xA1	0xB0	0x01	0x00	0x07	0x00	0x00	0x00	0x00	0x00	0x00	0x00	1
MIPI TX mode 0	0xE0	0xA1	0xB0	0x01	0x00	0x09	0x00	0x00	0x00	0x00	0x00	0x00	0x00	0
MIPI TX reset	0xE0	0xA1	0xB0	0x01	0x00	0x0A	0x00	0x00	0x00	0x00	0x00	0x00	0x00	1
Auto exposure on	0xE0	0xA1	0xB0	0x01	0x00	0x0C	0x00	0x00	0x00	0x00	0x00	0x00	0x00	1
Auto exposure off	0xE0	0xA1	0xB0	0x01	0x00	0x0C	0x00	0x00	0x00	0x00	0x00	0x00	0x00	0
Sleep mode active	0xE0	0xA1	0xB0	0x01	0x00	0x0D	0x00	0x00	0x00	0x00	0x00	0x00	0x00	0
Sleep mode S1	0xE0	0xA1	0xB0	0x01	0x00	0x0D	0x00	0x00	0x00	0x00	0x00	0x00	0x00	1

Table 7. Protocol write

Protocol name	Slave	Address	Slave	Return size	Description			
Byte order(Write)	-	0	1	2	3	-	-	
Register read	0xE0	0xA1	0xB2	0x11	0x22	0xE1	4	read address(0x2211)
Product name	0xE0	0xA1	0xB3	0xF0	0xF2	0xE1	8	000S100D(ASCII)
Firmware version	0xE0	0xA1	0xB3	0xF1	0xF2	0xE1	5	year/month/day/major/minor
Serial number	0xE0	0xA1	0xB3	0xF2	0xF2	0xE1	6	
Boot done	0xE0	0xA1	0xB3	0xF1	0xF1	0xE1	1	0 : not boot, 1 : boot

Table 8. Protocol read

7. MIPI interface

7.1. MIPI TX specification

- MIPI D-PHY 1.17 Nov 2011 compliant
- Forward (Unidirectional) high-speed only (LPDT/ULPS not support)
- HS diff.swing 200mV, HS common level 200mV
- Raw 10 data type supported
- Resolution mode
 - mode 0 : 2560x961
 - mode 1 : 1280x961
 - mode 2 : 640x961
- Frame rate : 30 fps
- MIPI CSI-2 2-lane (500Mbps/lane)
- First line : embedded frame head

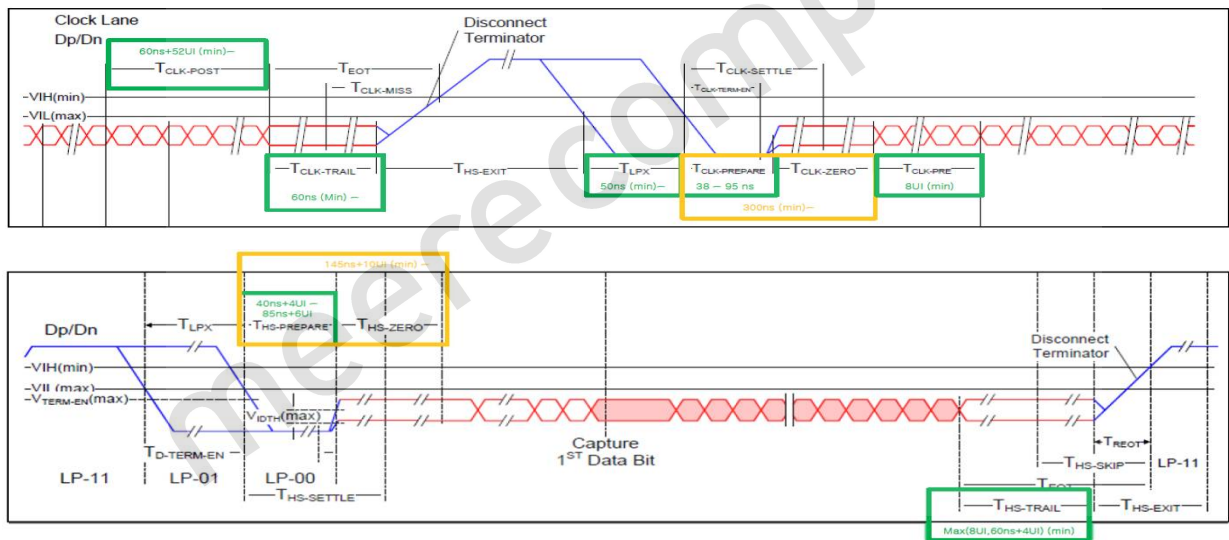

Fig 7. MIPI TX operation TX signal timing

8. Register Map

8.1. Register information

Address	31	30	29	28	27	26	25	24	23	22	21	20	19	18	17	16	15	14	13	12	11	10	9	8	7	6	5	4	3	2	1	0	Default value	Access
0x0028	amp_max_limit										amp_min_limit										0xFFFF0000	R/W												
0x0029	depth_max_limit										depth_min_limit										0xFFFF0000	R/W												
0x002A	scat_threshold										Reserved										0x0000200	R/W												
0x0030	depth_error_threshold																														0xFFFFFFFF	R/W		
0x0031	Reserved										Reserved										*1 *2 *3 *4	0x0DAC000F	R/W											
0x0033	Reserved										g_offset										0x80000000	R/W												
0x0039	flying pixel_threshold																														0x0000FFFF	R/W		
0x003A	Reserved															temporal_mblur															0x02000020	R/W		
0x003B	Reserved															mci_thresh															0x00000000	R/W		
0x003D	multi_freq_ctrl															Reserved															0xFF00C80	R/W		
0x0042	*5	Reserved																													0x00001D4C	R/W		
0x0046	set_tx_mode	data_format_sel	vcycle_dly										hcycle_dly										0x10003032	R/W										
0x0041	firm_rev_no										Reserved											R												
0x00AD	Reserved																													BD		R		
0x0127	Reserved																													mci_flag		R		

*1 : filter3 *2 : remove flying pixel *3 : filter2 *4 : filter1 *5 : filter3_ctrl

Table 9. Register information

8. Register Map

8.2. Register description

8.2.1. Amplitude threshold control registers

Register Name	Address	Bit	Default	Description
amp_max_limit	0x0028	[31:16]	0xFFFF	More than the set value, depth = 0 if(amplitude > amp_max_limit) depth = 0 else depth = depth
amp_min_limit	0x0028	[15:0]	0x0000	Less than the set value, depth = 0 if(amplitude < amp_min_limit) depth = 0 else depth = depth

Table 10. Amplitude threshold register setting

8.2.2. Depth threshold control registers

Register Name	Address	Bit	Default	Description
depth_max_limit	0x0029	[31:16]	0xFFFF	More than the set value, depth = 0 if(depth > depth_max_limit) depth = 0 else depth = depth
depth_min_limit	0x0029	[15:0]	0x0000	Less than the set value, depth = 0 if(depth < depth_min_limit) depth = 0 else depth = depth

Table 11. Depth threshold register setting

8.2.3. Scattering threshold control registers

Register Name	Address	Bit	Default	Description
scat_threshold	0x002A	[31:16]	0xFFFF	scat amplitude = Internally calculated value if(scat amplitude < scat_threshold) depth = 0 else depth = depth
Reserved	0x002A	[15:0]	0x0200	Do not change

Table 12. Scattering threshold register setting

8.2.4. Depth error threshold control registers

Register Name	Address	Bit	Default	Description
depth_error_threshold	0x0030	[31:0]	0xFFFFFFFF	error coefficient = Internally calculated value if(error coefficient > depth_error_threshold) depth = 0 else depth = depth

Table 13. Depth error threshold register setting

8. Register Map

8.2.5. Image filter control registers

Register Name	Address	Bit	Default	Description
Reserved	0x0031	[31:16]	0x0DAC	Do not change
Reserved	0x0031	[0]	0x1	Do not change
Reserved	0x0042	[15:0]	0x1D4C	Do not change
filter 3	0x0031	[4]	0x0	noise filter 3 on/off 1 = on, 0 = off
filter3_ctrl	0x0042	[31]	0x0	noise filter 3 change 1 = gaussian filter, 0 = default filter
remove flying pixel	0x0031	[3]	0x1	remove flying pixel on/off 1 = on, 0 = off
flying pixel_threshold	0x0039	[15:0]	0xFFFF	flying pixel coefficient = Internally calculated value if(flying pixel coefficient > flying pixel_threshold) depth = 0 else depth = depth
filter 2	0x0031	[2]	0x1	noise filter 2 on/off 1 = on, 0 = off
filter 1	0x0031	[1]	0x1	noise filter 1 on/off 1 = on, 0 = off

Table 14. Image filter register setting

8.2.6. Depth offset control registers

Register Name	Address	Bit	Default	Description
Reserved	0x0033	[31:16]	0x8000	Do not change
g_offset	0x0030	[15:0]	0x0000	Global offset value, Adds or subtracts from the depth value according to the set value (scale : 1mm).

Table 15. Depth offset register setting

8. Register Map

8.2.7. Motion blur control registers

Register Name	Address	Bit	Default	Description
temporal_mblur	0x003A	[7:0]	0x20	Temporal motion blur weight The motion blur is reduced as smaller input value (Input value range : 0x00 ~ 0xFF) As the input value decreases, the deviation of depth increases.
multi_freq_ctrl	0x003D	[31:23]	0x30	Multi-frequency motion blur weight The motion blur is reduced as smaller input value (Input value range : 0x00 ~ 0xFE) When set to 0xFF, multi-Frequency motion blur is completely removed, but aliasing always occurs. As the input value decreases, aliasing for moving objects increases.
multi_freq_ctrl	0x003D	[22:16]	0x01	Do not change

Table 16. Motion blur register setting

8.2.8. Multi camera interference control registers

Register Name	Address	Bit	Default	Description
mci_thresh	0x003B	[12:0]	0x00	mci threshold value mci_flag is generated by comparing the difference value between a the previous frame and the current frame. The difference value is the average value of a specific area. if $(frame(N-1) - frame(N) > mci\ thres\ value)$ mci_flag = '1' else mci_flag = '0'
mci_flag	0x0127	[3:0]	0x00	mci_flag consists of 4 bits, and each bit is the area information as follows. mci_flag[0] : area 1(left up side) mci_flag[1] : area 2(right up side) mci_flag[2] : area 3(left down side) mci_flag[3] : area 4(right down side)

Table 17. Multi camera interference reducing register setting

8. Register Map

8.2.9. Output data format control registers

Register Name	Address	Bit	Default	Description
set_tx_mode	0x0046	[31:28]	0x1	MIPI TX Resolution Selection 0x1 : XYZA 2560 * 961 0x2 : ZA 1280*961 0x4 : Z 640* 961
data_format_sel	0x0046	[0]	0x0	set_dist_sel[0] : Depth Output Selection 0x1 : R(Radial distance) 0x0 : Z(Point cloud)
		[1]	0x0	set_dist_sel[1] : Amplitude Output Selection 0x0 : Amplitude 0x1 : Intensity
		[3:2]	0x0	set_dist_sel[3:2] : MIPI TX Frame Selection 0x1 : 15 Fps 0x2 : 7.5 Fps default : 30 Fps
vcycle_dly	0x0046	[23:12]	0x000	vertical delay value Use it when setting the MIPI TX mode.
hcycle_dly	0x0046	[11:0]	0x000	horizontal delay value Use it when setting the MIPI TX mode.

Table 18. Output data format register setting

8.2.10. Information register

Register Name	Address	Bit	Default	Description
firm_rev_no	0x0041	[27:16]	0x21	firmware version information
BD	0x00AD	[0]	0x1	Boot status information 0x01 : idle, 0x01 : Boot done
sleep mode	TBD	TBD	TBD	sleep mode status information

Table 19. Module information register

9. Software(SDK)

9.1. Conditions of the example code (MIPI connection)

Environment

- Linux kernel version : 4.4.189
- V4L2 compatible
- Rockchip RK1109 compatible

Information

- file name : tof_lsi_mipi.c

9.2. CubeEye software development kit (USB3.0 connection)

libCubeEye is a cross-platform library for working with CubeEye camera (include S100D).

※ The SDK at a minimum includes :

- CubeEyeShell : This application can be used view, debug and set camera configurations and other controls.
- Code Examples : Examples to demonstrate the use of SDK to include S100D snippets into applications.
- Doc : Documents for use the SDK.

10. System Integration

10.1. System level block diagram

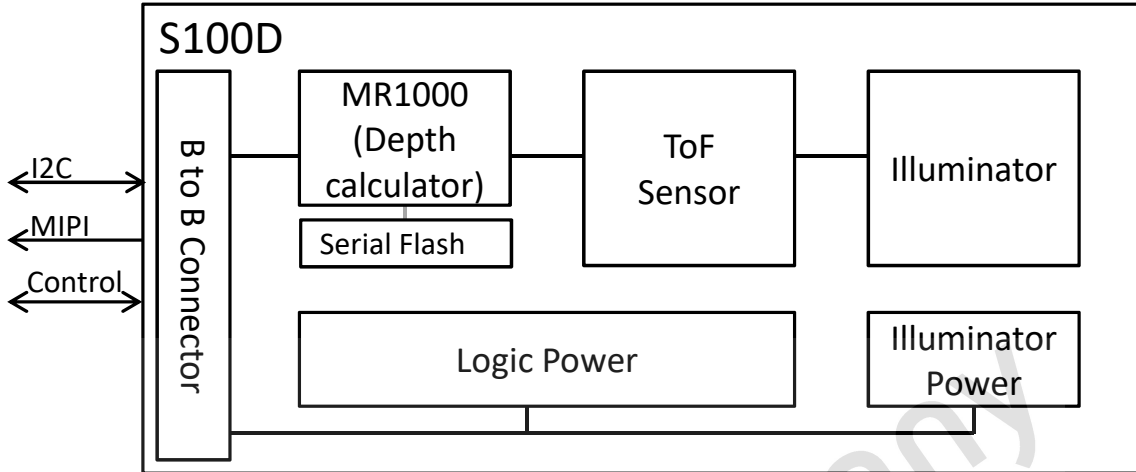

Fig 8. S100D system block diagram

10.2. System power

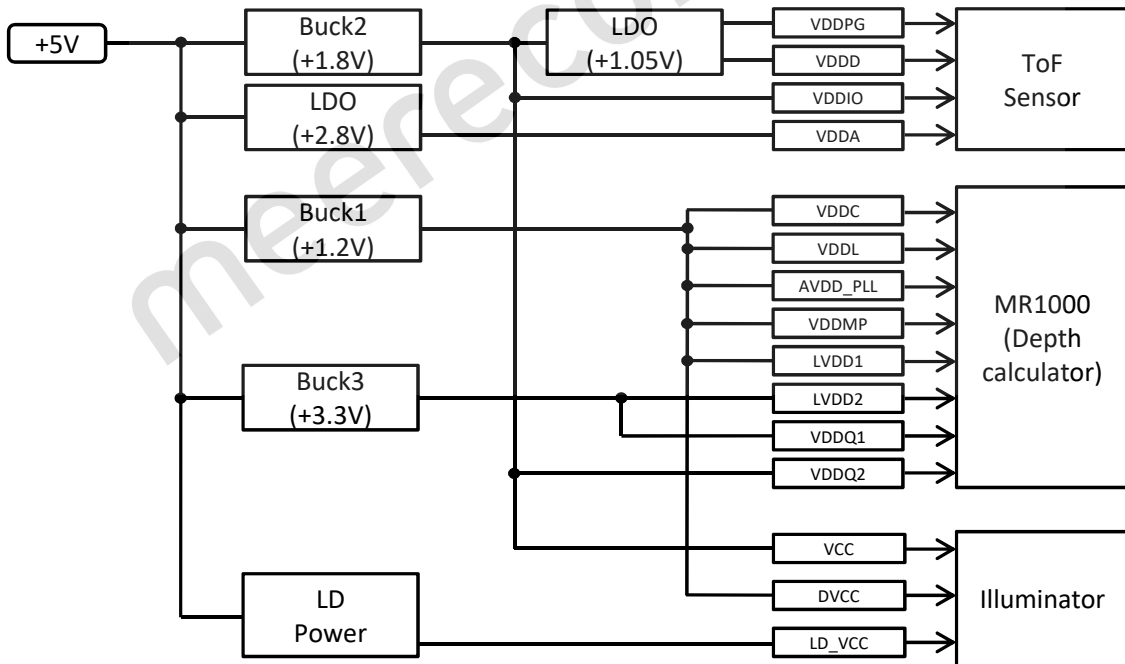

Fig 9. S100D system power

10. System Integration

10.3. B to B connector pin map(BBR50-04001-001)

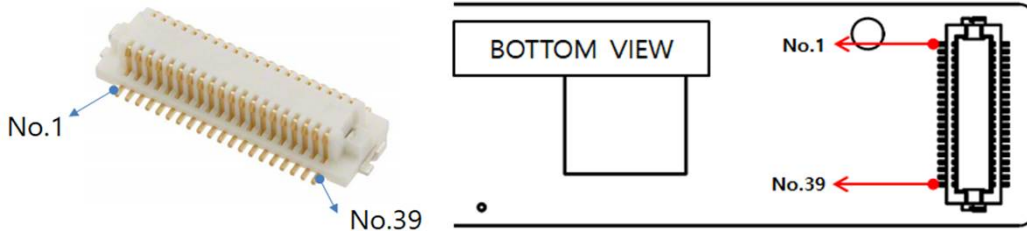

Fig 10. B to B connector No.1 position

Name	No.		Name
+5V	1	2	GND
+5V	3	4	GND
+5V	5	6	GND
+5V	7	8	GND
+5V	9	10	GND
+5V	11	12	GND
+5V	13	14	GND
GND	15	16	GND
LVDS_RX_P	17	18	LVDS_TX_P
LVDS_RX_N	19	20	LVDS_TX_N
GND	21	22	GND
MIPI_DATA0_P	23	24	Boot done
MIPI_DATA0_N	25	26	RESET
GND	27	28	LD Enable
MIPI_CLK_P	29	30	GPIO0
MIPI_CLK_N	31	32	GPIO1
GND	33	34	GPIO2
MIPI_DATA1_P	35	36	I2C_SDA
MIPI_DATA1_N	37	38	I2C_SCL
GND	39	40	Sync Input

Table 20. B to B connector pin map

10. System Integration

10.4. B to B connector pin information

Name	Description	Electrical Characteristics
+5V	ToF Module Power Input	5V/3A
MIPI_DATA0_N	MIPI data lane 0(negative)	MIPI
MIPI_DATA0_P	MIPI data lane 0(positive)	MIPI
MIPI_CLK_N	MIPI clock lane(negative)	MIPI
MIPI_CLK_P	MIPI clock lane(positive)	MIPI
MIPI_DATA1_N	MIPI data lane 1(negative)	MIPI
MIPI_DATA1_P	MIPI data lane 1(positive)	MIPI
LVDS_TX_P	Differential modulation clock output(positive)	LVDS
LVDS_TX_N	Differential modulation clock output(negative)	LVDS
LVDS_RX_P	Differential modulation clock input(negative)	LVDS
LVDS_RX_N	Differential modulation clock input(positive)	LVDS
Boot done	Booting Done : Active High	1.8V
RESET	Reset : Active Low	1.8V
LD ENABLE	Laser Diode(VCSEL) Enable : Active Low	1.8V
GPIO	General Purpose I/O	1.8V
I2C_SDA	I2C Serial Data(Slave)	1.8V
I2C_SCL	I2C Serial Clock(Slave)	1.8V
Sync Input	Second camera SYNC signal : Input	1.8V

Table 21. B to B connector pin information

11. Design Guidelines

11.1. LVDS line PCB design guide(Mandatory)

- Assign those two pair of pins as close as possible, to be connected in the shortest path on the host PCB.
- Line length should be the same.
- Design with an impedance of 100 ohm.

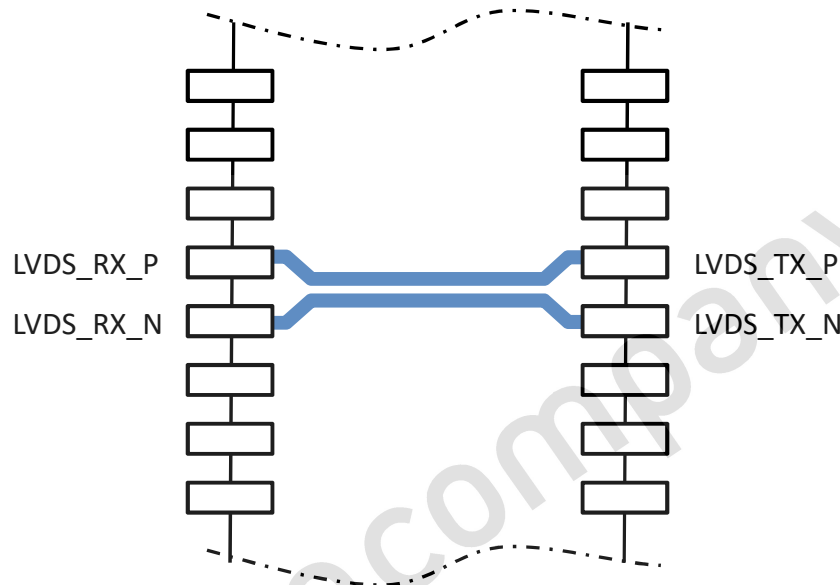

Fig 11. Host PCB LVDS line design guide

11.2. MIPI signals artwork guide

- Keep the length difference of the differential traces less than 1mm.
- Design with an impedance of 100 Ω

11.3. Notes on design

- Design the host PCB, the connector pin 1 position should not be changed
- The specified power must be supplied to the ToF camera module

12. Mechanical Drawings

12.1. Schematic

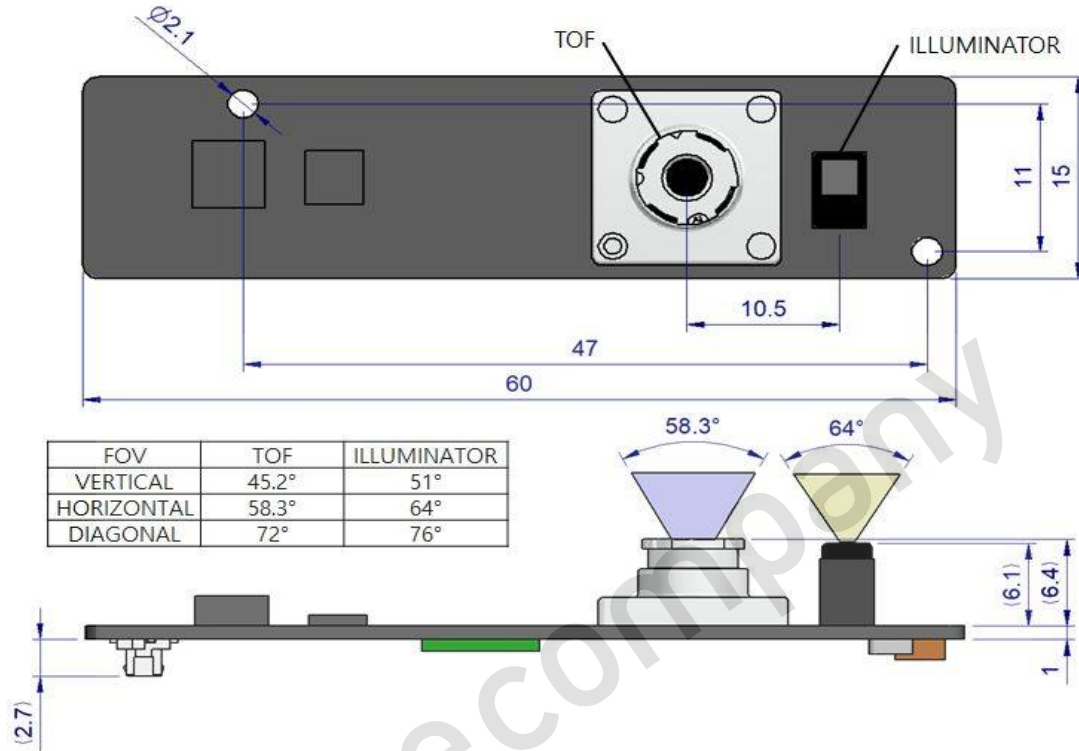

Fig 12. S100D dimension and schematic

12.2. Physical z=0 plane

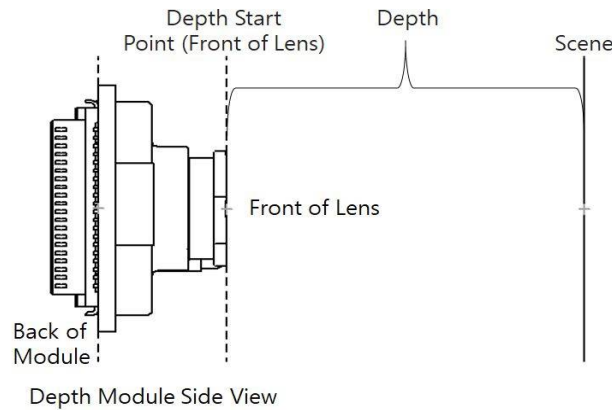

Fig 13. Physical z=0 plane

13. Connector Drawings

13.1. S100D B to B connector drawing(BBR50-04001-001)

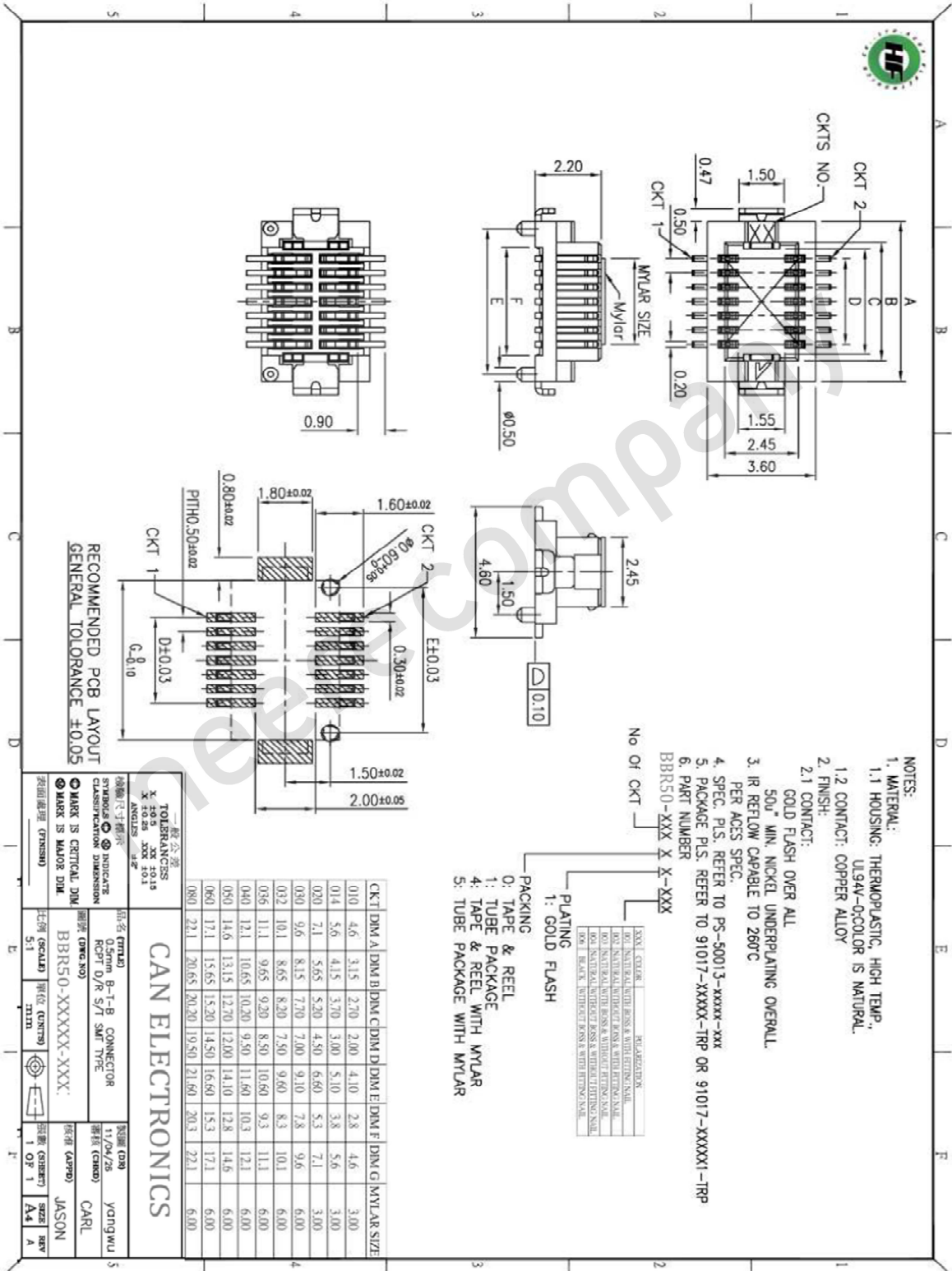

Fig 14. S100D connector



13. Connector Drawings

13.2. Host board connector drawing (DF12NB(5.0)-40DP-0.5V(51))

■Header With Solder Tab

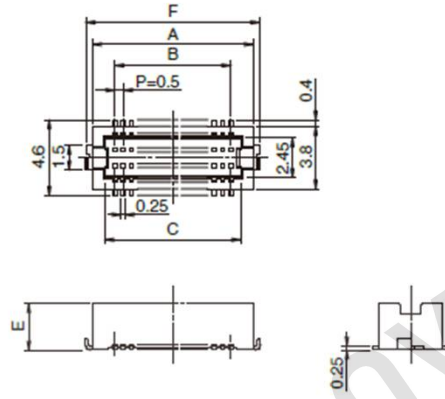

●Stacking Height : 3.5 to 5mm Product

Unit : mm

Part No.	HRS No.	No. of Pos.	A	B	C	E	F	Remarks	RoHS
DF12NB(3.5)-20DP-0.5V(51)	537-0493-0 51	20	7.2	4.5	5.7	2.8	8.1	With Solder Tab	YES
DF12NB(3.5)-30DP-0.5V(51)	537-0494-0 51	30	9.7	7.0	8.2		10.6		
DF12NB(3.5)-36DP-0.5V(51)	537-0495-0 51	36	11.2	8.5	9.7		12.1		
DF12NB(3.5)-40DP-0.5V(51)	537-0496-0 51	40	12.2	9.5	10.7		13.1		
DF12NB(3.5)-50DP-0.5V(51)	537-0497-0 51	50	14.7	12.0	13.2		15.6		
DF12NB(3.5)-60DP-0.5V(51)	537-0498-0 51	60	17.2	14.5	15.7		18.1		
DF12NB(4.0)-20DP-0.5V(51)	537-0592-0 51	20	7.2	4.5	5.7	3.3	8.1		
DF12NB(4.0)-30DP-0.5V(51)	537-0593-0 51	30	9.7	7.0	8.2		10.6		
DF12NB(4.0)-32DP-0.5V(51)	537-0594-0 51	32	10.2	7.5	8.7		11.1		
DF12NB(4.0)-36DP-0.5V(51)	537-0595-0 51	36	11.2	8.5	9.7		12.1		
DF12NB(4.0)-40DP-0.5V(51)	537-0596-0 51	40	12.2	9.5	10.7		13.1		
DF12NB(4.0)-50DP-0.5V(51)	537-0597-0 51	50	14.7	12.0	13.2		15.6		
DF12NB(4.0)-60DP-0.5V(51)	537-0598-0 51	60	17.2	14.5	15.7	18.1			
DF12NB(5.0)-20DP-0.5V(51)	537-0877-0 51	20	7.2	4.5	5.7	4.3	8.1		
DF12NB(5.0)-30DP-0.5V(51)	537-0878-0 51	30	9.7	7.0	8.2		10.6		
DF12NB(5.0)-36DP-0.5V(51)	537-0879-0 51	36	11.2	8.5	9.7		12.1		
DF12NB(5.0)-40DP-0.5V(51)	537-0880-0 51	40	12.2	9.5	10.7		13.1		
DF12NB(5.0)-50DP-0.5V(51)	537-0881-0 51	50	14.7	12.0	13.2		15.6		
DF12NB(5.0)-60DP-0.5V(51)	537-0882-0 51	60	17.2	14.5	15.7		18.1		

Note : Please order the embossed tape packaging product per reel. (1,000pcs/reel)

Fig 15. Host board Connector

14. Certification

14.1. Eye safety

Standard	Result
IEC 60825-1:2014 (Third Edition)	Class 1

Table 22. Eyesafety standard information

meerecompany

Appendix A : Data Format

A.1. Data format - Raw 10 bits (16 bits unsigned int)

The S100D has 3 output modes as shown in the table below.(Default : mode 0)
Each (Z/R) and (Amplitude/Intensity) is selectable and the default is Z, Amplitude.

mode	Resolution	Position(Z/R selectable)			IR(selectable)
		X	Y	Z / R	Amplitude / Intensity
mode 0	2560 x 961	○	○	○	○
mode 1	1280 x 961	-	-	○	○
mode 2	640 x 961	-	-	○	-

Table 23. Data mode

A.1.1. 1 pixel format

Each mode has a different pixel size. Attention is required in these situations.

mode 0 (64bits): 1pixel (16bits X, 16bits Y, 16bits Z, 16bits A)

mode 1 (32bits): 1pixel (16bits R, 16bits A)

mode 2 (16bits): 1pixel (16bits R)

A.1.2. 16 bits Data format

Complexly, it imports two 10-bit raw MIPI data to convert one 16-bit.
The 16-bit data generated becomes a component of the pixel.

2 MIPI Raw 10 bits to 16 bits data

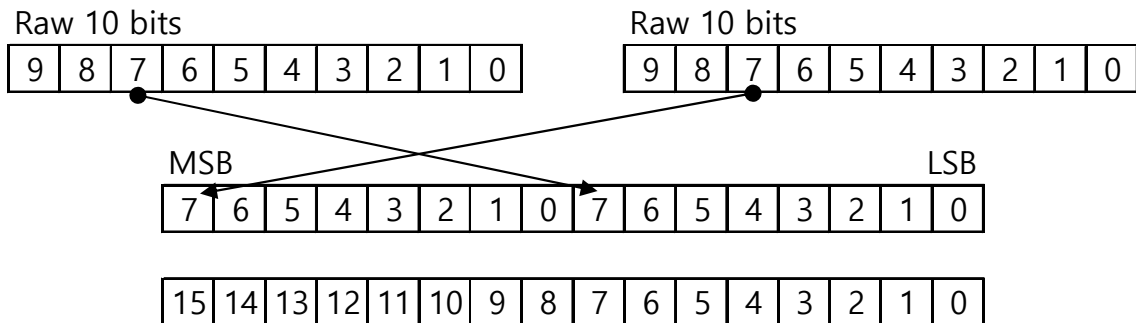

Fig 16. Data reconstruction

Appendix A : Data Format

A.2. Mode example

Expression rule

X - * _ # _ \$

X : data information

* : pixel x index

: pixel y index

\$: L(LSB) H(MSB)

Em - #

Em : embedded data

: data index

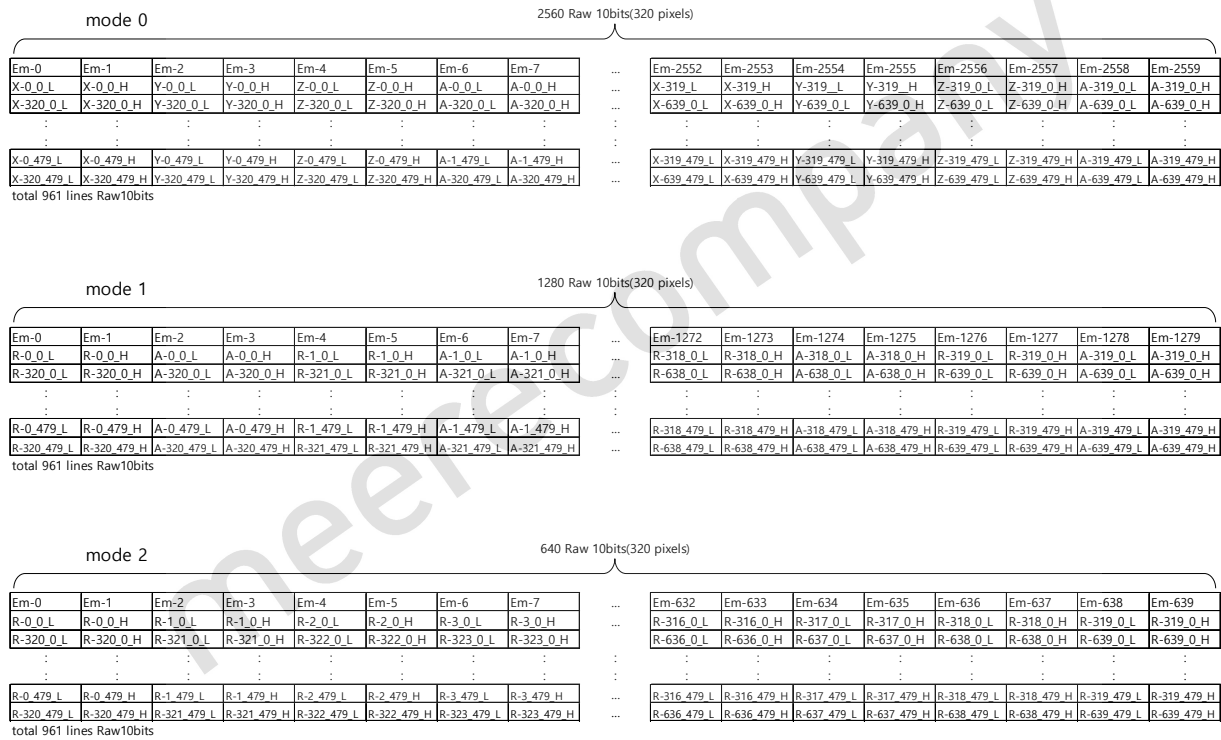

Fig 17. Output mode examples



Appendix A : Data Format

A.3. Embedded line data description

Data index	Bus_width	Name	Description
Em-0	8	rev_no[7:0]	MR1000 Revision number
Em-6	8	frame_count[7:0]	frame_count[7:0]
Em-7	8	frame_count[15:8]	frame_count[15:8]
Em-8	1	filter3_on[7]	filter3_on/off
	1	remove_flying_pixel_on[6]	remove_flying_pixel_on/off
	1	filter2_on[5]	filter2_on/off
	1	filter1_on[4]	filter1_on/off
Em-12	8	set_firm_rev_no[7:0]	firmware Revision number
Em-17	8	tof_temp[7:0]	ToF temperature = tof_temp[15:0] * 256
Em-18	8	tof_temp[15:8]	
Em-19	8	drv_temp[7:0]	drive IC temperature = drv_temp[15:0] * 256
Em-20	8	drv_temp[15:8]	
Em-21	8	amp_max_limit[7:0]	amp_max_limit
Em-22	8	amp_max_limit[15:8]	
Em-23	8	amp_min_limit[7:0]	amp_min_limit
Em-24	8	amp_min_limit[15:8]	
Em-25	8	depth_max_limit[7:0]	depth_max_limit
Em-26	8	depth_max_limit[15:8]	
Em-27	8	depth_min_limit[7:0]	depth_min_limit
Em-28	8	depth_min_limit[15:8]	
Em-29	8	mci_thresh[7:0]	mci_thresh
Em-30	8	mci_thresh[15:8]	
Em-35	4	mci_flag[3:0]	mci_flag
Em-38	8	scat_threshold[7:0]	scat_threshold
Em-39	8	scat_threshold[15:8]	
Em-40	8	flying_pixel_threshold[7:0]	remove_flying_pixel_thresh
Em-41	8	flying_pixel_threshold[15:8]	
Em-42	8	temporal_mblur[7:0]	temporal_mblur
Em-43	8	multi_freq_ctrl[7:0]	multi_freq_ctrl
Em-68	4	data_format_sel[3:0]	data_format_sel[3:0]
Em-73	8	g_offset[7:0]	global_offset
Em-74	8	g_offset[15:8]	

Table 24. Embedded line data description

Appendix B : USB3.0 bridge board(U300)

B.1. Block Diagram

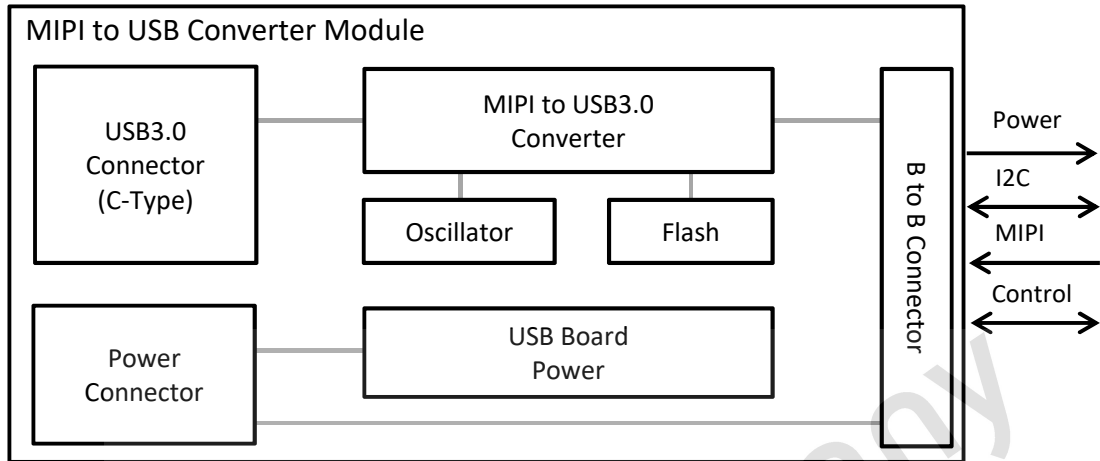

Fig 18. U300 block diagram

B.2. S100D on U300

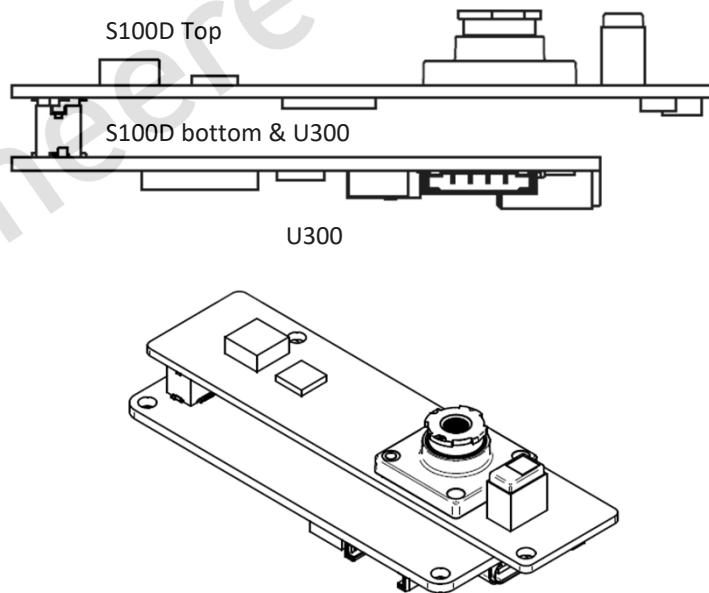

Fig 19. Combined S100D and U300

Appendix B : USB3.0 bridge board(U300)

B.3. U300 schematic

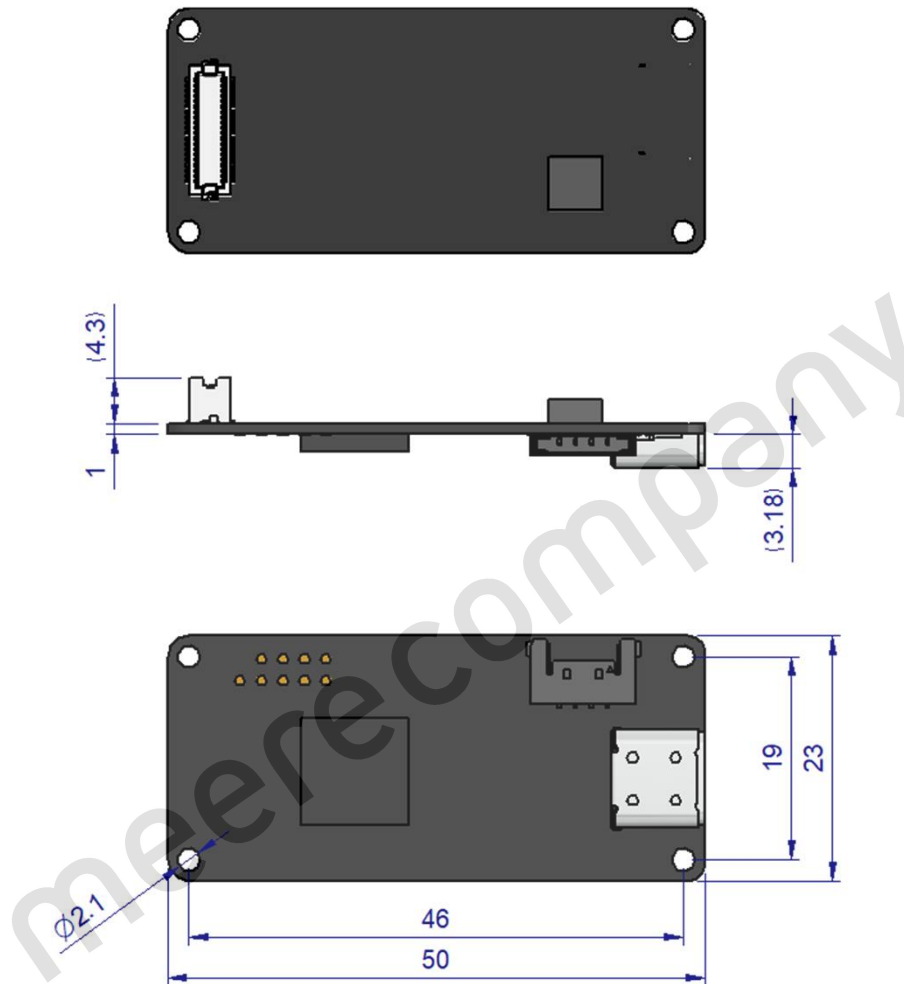

Fig 20. U300 dimension

Appendix B : USB3.0 bridge board(U300)

B.4. U300 connector pin map(DF12NB(5.0)-40DP-0.5V(51))

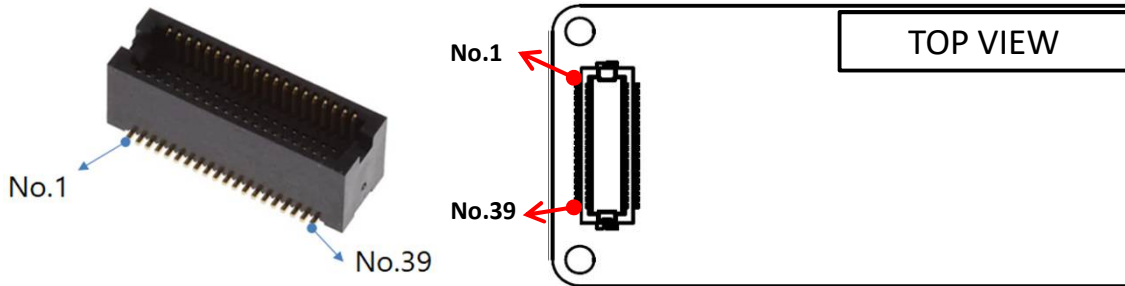

Fig 21. U300 B to B connector

Name	No.		Name
GND	1	2	+5V
GND	3	4	+5V
GND	5	6	+5V
GND	7	8	+5V
GND	9	10	+5V
GND	11	12	+5V
GND	13	14	+5V
GND	15	16	GND
LVDS_RX_P	17	18	LVDS_TX_P
LVDS_RX_N	19	20	LVDS_TX_N
GND	21	22	GND
Boot done	23	24	MIPI_DATA0_P
RESET	25	26	MIPI_DATA0_N
N.C	27	28	GND
GPIO0	29	30	MIPI_CLK_P
GPIO1	31	32	MIPI_CLK_N
GPIO2	33	34	GND
I2C_SDA	35	36	MIPI_DATA1_P
I2C_SCL	37	38	MIPI_DATA1_N
N.C	39	40	GND

Table 25. U300 B to B connector pin map

Appendix B : USB3.0 bridge board(U300)

B.5. U300 connector pin Information

Name	Description	Electrical Characteristics
+5V	ToF Module Power Input	5V/3A
MIPI_DATA0_N	MIPI data lane 0(negative)	MIPI
MIPI_DATA0_P	MIPI data lane 0(positive)	MIPI
MIPI_CLK_N	MIPI clock lane(negative)	MIPI
MIPI_CLK_P	MIPI clock lane(positive)	MIPI
MIPI_DATA1_N	MIPI data lane 1(negative)	MIPI
MIPI_DATA1_P	MIPI data lane 1(positive)	MIPI
LVDS_RX_P	Differential modulation clock input(positive)	LVDS
LVDS_RX_N	Differential modulation clock input(negative)	LVDS
LVDS_TX_P	Differential modulation clock output(negative)	LVDS
LVDS_TX_N	Differential modulation clock output(positive)	LVDS
Boot done	Booting Done : Active High	1.8V
RESET	Reset : Active Low	1.8V
GPIO	General Purpose I/O	1.8V
I2C_SDA	I2C Serial Data(Slave)	1.8V
I2C_SCL	I2C Serial Clock(Slave)	1.8V

Table 26. U300 pin information

Appendix B : USB3.0 bridge board(U300)

B.6. Accessories

- Adaptor
- Power Cable
- USB3.0 Cable(A to C-type)



Fig 22. U300 accessories

B.7. Cable connection

- Power Cable/USB Cable connection

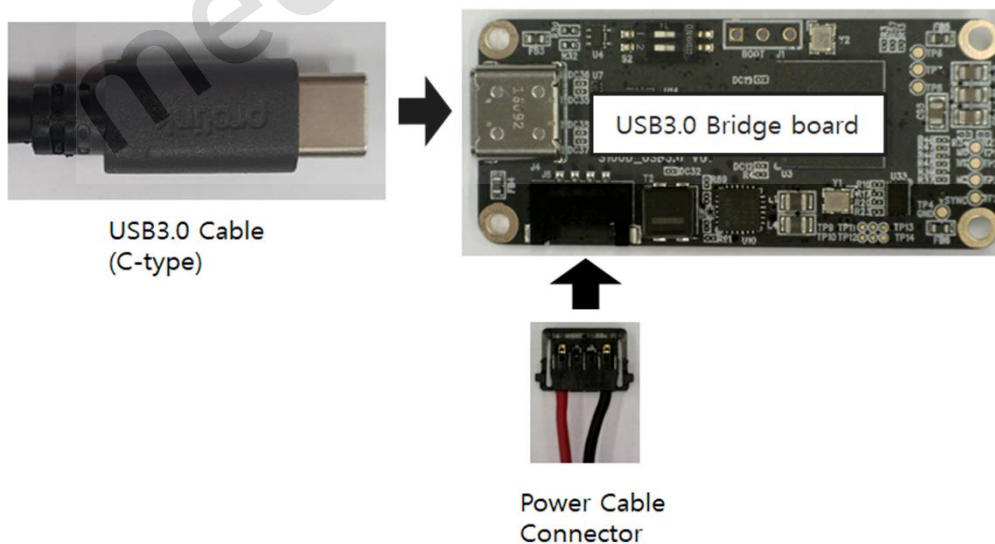

Fig 23. Cable connection

Appendix C : Part Number

Configuration of part number

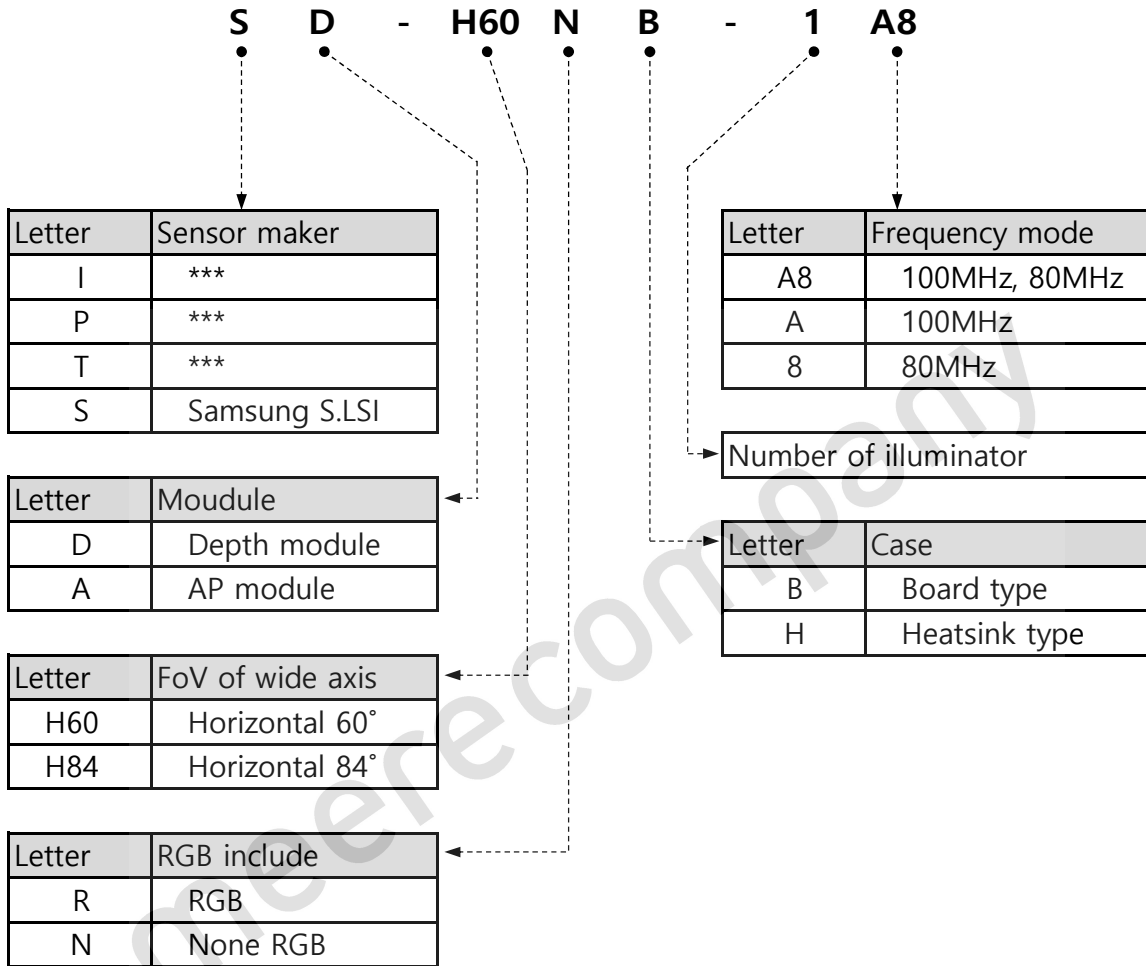

Fig 24. Decription of the part number configuration

Appendix D : Cover Glass Assy' Guide

When using the cover glass, it is recommended to place it as close to the lens as possible. And it is necessary to place a light barrier between RX and TX to minimize light spread.

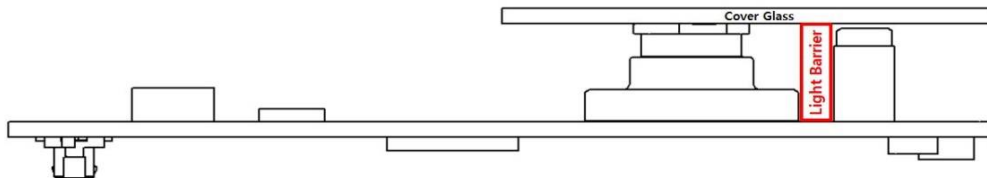

Fig 25. Example image of use of cover glass

meerecompany